

ZDUE-LTE-PLUS-VII Installation Instructions

Safety Notes



Incorrect installation, commissioning or operation can lead to serious damage to property and personal injury and to death.

Please read these instructions carefully before installing, commissioning and using the ZDUE-LTE-PLUS-VII. Use the appliance only as described in the data sheet and the manual.

The ZDUE-LTE-PLUS-VII meets the requirements of safety standard EN 62368-1 (protection class 2).

Qualified personnel:

Installation and commissioning of the ZDUE-LTE-PLUS-VII and the accessories may only be carried out by electricians. They must be trained and qualified to detect and avoid hazards and to install, commission, ground and mark appliances, systems and circuits in accordance with the standards and recognized rules of technology

Connection to the house installation:

An easily accessible, all-pole circuit breaker in the power supply circuit is required for the house installation. Alternatively, a single-pole circuit breaker can be used in the outer conductor as long as a distinct neutral conductor has been integrated into the supply line. Observe country-specific regulations. In Germany, the circuit breaker must at least meet the requirements of the DIN VDE series 0100 standards (see CENELEC HD384; IEC 60364).

For the house installation, there must be an installation fuse that complies with the DIN VDE series 0100 standards (see CENELEC HD384; IEC 60364) and is properly adapted to the cable cross-section of the power supply line. The additional short-circuit protection must have a selectivity of $I \geq 1500A$.

The appliance is not suitable for connection to an electrical supply network with IT configuration (IT system).

Cable Routing:

The space between antenna/data lines and lines carrying dangerous voltages must be at least 10 mm.

Location:

Never use the ZDUE-LTE-PLUS-VII in areas where the operation of radio equipment is prohibited. The appliance contains a radio transmitter, which can possibly impair the function of medical electrical appliances such as hearing aids or cardiac pacemakers.

The ZDUE-LTE-PLUS-VII is suitable for use in overvoltage category III. If the appliance is likely to be exposed to higher transient over voltages than those in overvoltage category III when connected, it will be necessary to take further safety precautions for the installation.

Antenna Installation

Indoor and outdoor antennas of the appliance may be installed and operated only with a minimum distance of 20 cm from humans.

The antennas must be installed and operated so that they do not interfere with other antennas or devices.

When using a directional antenna, observe the legal limit for electromagnetic fields (0 Hz to 300 GHz) in public areas. For details, see Council Recommendations 1999/519/EC of 12 July 1999.

It is mandatory, that the installation of an outdoor antenna must be carried out by a qualified electrician. The standards EN 60728-11 and VDE 0855-300 as well as any other national installation guidelines for lightning protection must be followed.

Intended Use

The ZDUE-LTE-PLUS-VII is an appliance designed for the remote inquiry and the remote monitoring of electricity, heat, gas and water meters. It is design to be used in mobile radio networks.

Opening the device

In order to insert the SIM card or to access the DIP switch, you first have to open the device:

1. First disconnect all the poles of the device from the electricity supply if it is plugged in there.
2. Now unscrew the screw in the terminal cover and remove the cover.
3. Now remove the device lid.

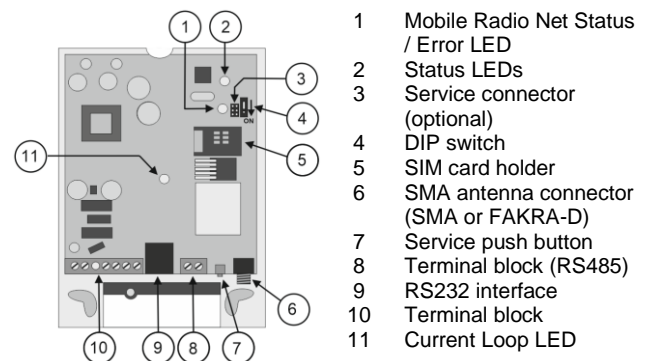

Altering the device settings

Using the DIP switch (4) you toggle between the both operating modes, meter mode and AT command mode.

In meter mode (OFF), the device can be adjusted locally via one of the meter interfaces or remotely via communication commands according to EN 62056-21. In this case, the device will then operate using the parameters that have been set.

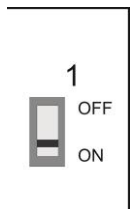

Setting the PIN of the SIM card

In order to operate the ZDUE-LTE-PLUS-VII, you will require a plug-in SIM card (1,8V or 3V) from a mobile radio network operator. A ZDUE-LTE-PLUS-VII having factory default settings expects a SIM card with a PIN 0000. The PIN setting of the ZDUE-LTE-PLUS-VII can be changed in the device settings.

Inserting the SIM card

Insert the SIM card as follows:

1. Open the SIM card holder by gently pressing the lid towards the edge of the device, flip it up and insert the SIM card into the slot in the holder. The gold-plated contacts on the SIM card have to lie on the gold-plated contacts of the holder when the holder is closed.
2. Close the lid of the SIM card holder and lock it by pressing it gently back towards the center of the device. You will feel it click into place.
3. Now replace the device lid and the terminal cover.

Connecting the device

First connect the meter to the device and then connect the power supply.

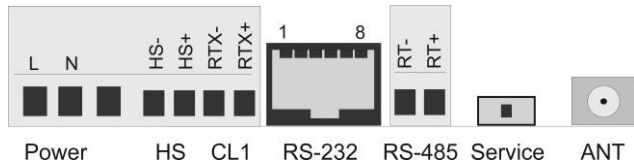

The device is equipped with 3 different meter interfaces, which are wired in parallel.

RS232 interface (RJ45 jack):

Pin	Signal	Description
2	DSR	Output; Always active
4	GND	Signal ground
5	TXD	Output; Data to meter
6	RXD	Input; Data from meter

Signals and levels according to V.24 / V.28.
All other pins are reserved.

RS485 interface (terminal block):

Signal	Description
RT-	Negative RS-485 interface signal
RT+	Positive RS-485 interface signal

Dual-wire RS485 interface to connect up to 32 transceivers. The bus connection is terminated to $Z=120\ \Omega$ (nominal) (RT+ to RT-) and the cable length is limited to 1000m.

CL1 interface (terminal block) / optional:

Signal	Description
RTX-	Negative CL1 interface signal
RTX+	Positive CL1 interface signal

20mA power interface (current loop) to connect meters with the power supply interface according to DIN EN 62056-21. Approx. 4 meters can be connected to this interface.

The CL1 interface is optional. Devices without CL1 interface do not contain RTX- / RTX+ terminals. Please refer to the label of the terminal block.

Important:
If no meter is connected to the CL1 interface, the RTX- and RTX+ contacts need to be short-circuited. Otherwise, the other interfaces will not operate.

Auxiliary power source (HS; terminal block):

Signal	Description
HS-	Negative pole of the auxiliary power supply
HS+	Positive pole of the auxiliary power supply

Auxiliary power supply of 9V / max. 100mA
The auxiliary power supply is not available for all the ZDUE-LTE-PLUS-VII models.

Power supply (terminal block):

Signal	Description
L	AC: $U_{nom} = 100VAC \dots 230VAC$
N	DC: $U_{nom} = 80VDC \dots 230VDC$

$I_{nom} = 120mA / 40mA$

Connecting the antenna

Observe the safety instructions for antenna mounting. Follow the instructions that came with your antenna. The antenna must have the following characteristics: passive, gain $<2.3\ dBi$, VSWR $<2:1$, impedance $50\ \Omega$, adapted for the used frequency bands. Use antennas from the accessory range of the ZDUE.

The antenna is connected to the type SMA or type FAKRA-D antenna jack (ANT). The antenna should be installed to ensure adequate signal quality. Ensure that there are no large metal objects (e.g. reinforced concrete) near the antenna, as these will adversely affect the signal quality.

Light-emitting diodes (LEDs)

Status LED (2) / Green & Orange with light pipe

Permanently green	Supply voltage available
Permanently orange	Mobile radio module on

Depending on the firmware version, both LEDs may be off in case of a missing or defect SIM card.

Current Loop LED (11)

Permanently green	Meter connected to the CL1 interface or CL 1 interface short-circuited.
-------------------	---

Mobile Radio Status-/Error LED (1) / Orange

$\approx 3s$ on / 3 x flashing	Network search
$\approx 3s$ on / 2 x flashing	Error status
$\approx 3s$ on / 1 x flashing	SIM/PIN error
Permanently off	Signal strength unknown
$\approx 3s$ off / 1-4 x flashing	Signal strength (1=low; 4=high)
Permanently on	Mobile radio connection active

This LED operates in meter mode only.

Service push button (7)

Push the button 1x for more than 5 seconds.	The parameters being set by EN 62056-21 commands will be deleted and the factory settings are reloaded.
Push the button when switching the power on.	The actual firmware version will be output at the local interface (19200bps; 8N1).

The service push button operates in meter mode only.

Simplified EU Declaration of Conformity

Hereby, Sagemcom Dr. Neuhaus GmbH declares that the radio equipment ZDUE-LTE-PLUS-VII is in compliance with Directive 2014/53/EU. The full text of the EU declaration of conformity is available at the following internet address:

www.sagemcom.com/neuhaus

Frequency bands: GSM/GPRS/EDGE: 900/1800MHz
UMTS/HSPA+: 900/2100MHz
LTE: 700/800/900/1800/2100/2600MHz

Transmit power: max. 33dBm = 2W bei GSM 900
max. 30dBm = 1W bei GSM 1800
max. 24dBm = 0,25W bei UMTS/HSPA+
max. 23dBm = 0,20W bei LTE

Copyright Statement

The information published in this document is under copyright. Any translations, reprints, reproduction and storage in data-processing systems require the express prior consent of the manufacturer.

Subject to technical modification.

All trademarks and product names are trademarks, registered trademarks or product names of the respective owners. All information is based on the information provided by the manufacturer. No guarantee or liability will be assumed for any error or omissions. The contents of this handbook and the technical specifications may change without prior notice. The descriptions of the specifications in these instructions do not in any way represent a contract.

© Sagemcom Dr. Neuhaus GmbH
Doc.-No. 8230AD002 / Version 1.3 / March 2024